

# AD2006 TELEMETRY MODULE

## QUICKSTART MANUAL

AD2006 (Revision 4)



**Note:** Before applying power, ensure that the power supply and all wiring is correctly connected. The product warranty does not cover installation error.

## Contents

|           |   |          |
|-----------|---|----------|
| <b>1.</b> | <b>Scope of this Manual</b> .....                 | <b>1</b> |
| <b>2.</b> | <b>Ordering Information</b> .....                 | <b>1</b> |
|           | Part Numbers / Ordering Code .....                | 1        |
| <b>3.</b> | <b>Technical Information</b> .....                | <b>2</b> |
|           | <b>Overall Arrangement</b> .....                  | <b>2</b> |
|           | LED Indicators .....                              | 2        |
|           | <b>Inputs</b> .....                               | <b>3</b> |
|           | Analog Inputs .....                               | 3        |
|           | Digital Inputs .....                              | 3        |
|           | Pulse Counters .....                              | 4        |
|           | <b>Digital Outputs</b> .....                      | <b>4</b> |
|           | <b>Ports</b> .....                                | <b>5</b> |
|           | Port 1 – External Radio - FFSK or RS232 .....     | 5        |
|           | Ports 2 & 5 - RS232 .....                         | 5        |
|           | Port 3 - RS485.....                               | 5        |
|           | Port 4 - USB-B.....                               | 5        |
|           | Port 5 - Ethernet Option .....                    | 5        |
|           | <b>Radios</b> .....                               | <b>6</b> |
|           | Internal Radios .....                             | 6        |
|           | External Radio .....                              | 6        |
|           | Baud Rate Options .....                           | 6        |
| <b>4.</b> | <b>Options</b> .....                              | <b>7</b> |
|           | Analog Output.....                                | 7        |
|           | Power Supply Monitor .....                        | 7        |
|           | Voltage Source for Field Sensors .....            | 7        |
| <b>5.</b> | <b>Antennas</b> .....                             | <b>8</b> |
|           | Vertically Polarised 450 – 470 MHz Antennas ..... | 8        |
| <b>6.</b> | <b>Wiring &amp; Mounting</b> .....                | <b>9</b> |
|           | <b>Wiring</b> .....                               | <b>9</b> |
|           | <b>Mounting</b> .....                             | <b>9</b> |

# 1. Scope of this Manual

This manual is intended to provide sufficient information for the correct installation of your AD2006 telemetry module. Your AD2006 module will be delivered pre-configured to your project specifications where requested, or set to factory defaults as specified in this manual.

For programming information please refer to the MiriMap 2000+ Software on-line help.

# 2. Ordering Information

There are many variations of the AD2006 telemetry modules available. The following shows the ordering code and details for modules with or without internal data radios. For other radio or modem options please contact Miri directly.

The following options are not fitted as factory standard and need to be requested when ordering;

- 4 Channel Analog Output Option
- Ethernet Port Option

**Please Note:** If you are ordering a module to add to an existing system, please be sure to specify the project name when ordering the new module.

The AD2006 part number is displayed on the rear of each unit together with other relevant information.

|  |  |
|--|--|
| <b>AD2006R-M5125-LN-12</b>   |  |
| Hardware version - Rev. 4  | serial no <input type="text" value="10462"/> |
| Tx frequency - 450.650 MHz   | special <input type="text"/>                 |
| Rx frequency - 450.650 MHz   |  |
| Brockman <input type="text" value="Return Water Pumps"/>                             |  |
| Miri Technologies - Perth, West Australia. tel. +61 8 9409 8998 fax. +61 8 9409 9229 |  |

## Part Numbers / Ordering Code

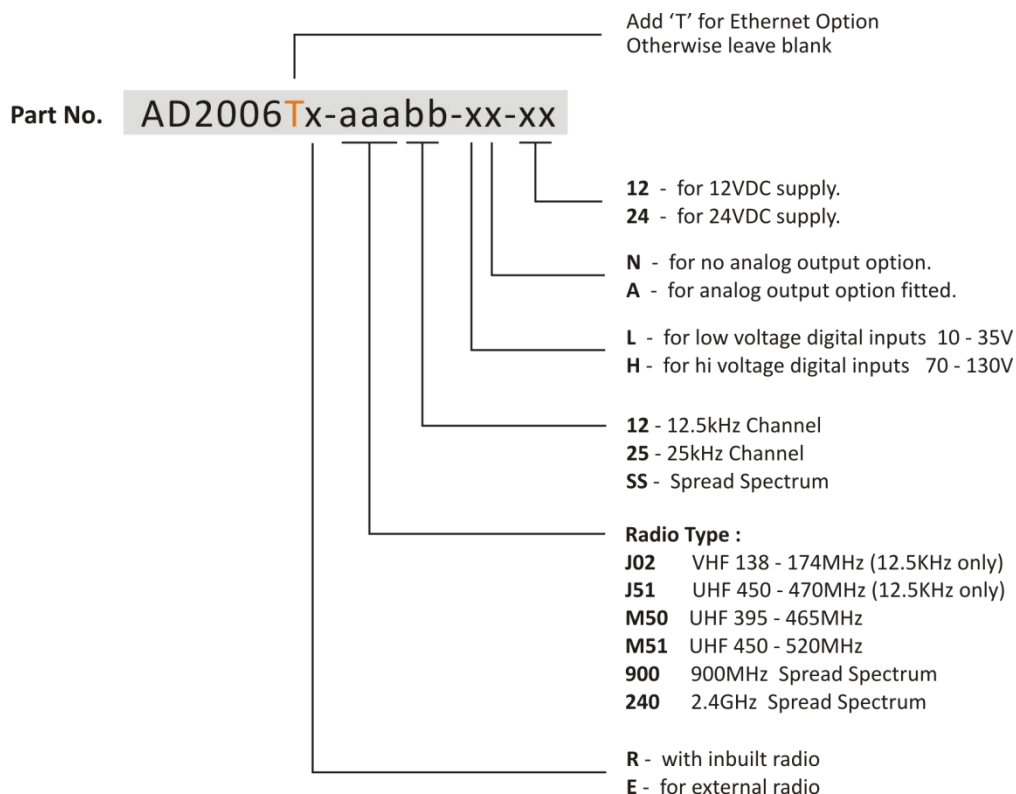

### 3. Technical Information

#### Overall Arrangement

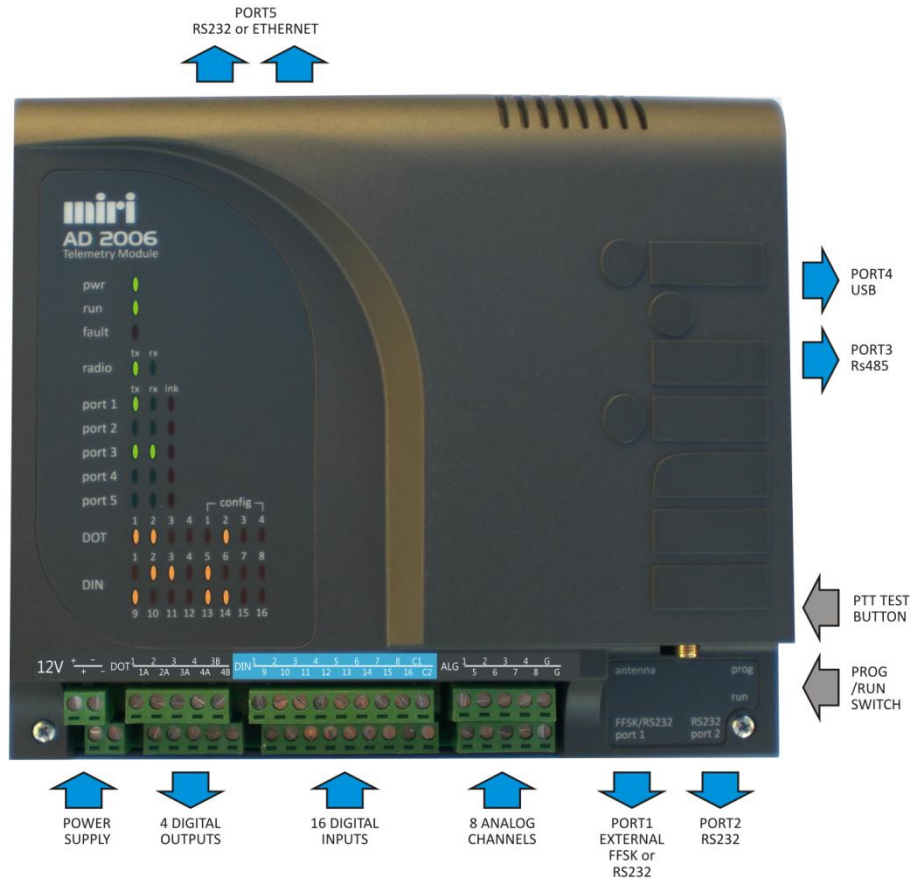

#### LED Indicators

- pwr** ● The pwr LED should be on at all times when the unit is powered up.
- run** ● The run LED should flash at 2Hz when the unit is in RUN mode and 4Hz in PROG mode.
- fault** ● A fault means that the module has received a bad reply to a message.
- radio**
  - tx ● rx ●

The tx and rx LEDs reflect the PTT and CD status of the internal radio.
- port 1**
  - tx ● rx ● lnk ●

The tx and rx LEDs for each port indicate that a valid system message has been sent or received on that port. A link indication means that the slave time-out period for that port has lapsed or the programmed number of retries have failed and communications have been lost.
- port 2**
  - tx ● rx ● lnk ●
- port 3**
  - tx ● rx ● lnk ●
- port 4**
  - tx ● rx ● lnk ●
- port 5**
  - tx ● rx ● lnk ●
- DOT**
  - 1 ● 2 ● 3 ● 4 ● 1 ● 2 ● 3 ● 4 ●

The first four LEDs indicate that the physical outputs are active. The second four LEDs are programmable status indications.
- DIN**
  - 1 ● 2 ● 3 ● 4 ● 5 ● 6 ● 7 ● 8 ●
  - 9 ● 10 ● 11 ● 12 ● 13 ● 14 ● 15 ● 16 ●

These LEDs indicate that a particular input is active.

## Inputs

### Analog Inputs

The AD2006 module has 8 analog input channels with a common ground. These are factory configured to 4-20mA.

The following options are available by jumper selection;

- 0-20mA / 0-5V
- 4-20mA / 1-5V
- 0-1V



**Note:** Whichever option is selected determines the configuration of all analog input channels.

Channels 1 to 8 are configured for current or voltage inputs via jumpers J35 to J42 respectively. If a jumper is installed in the appropriate location then that channel will operate as a current input. If no jumper is installed, it will operate as a voltage input.

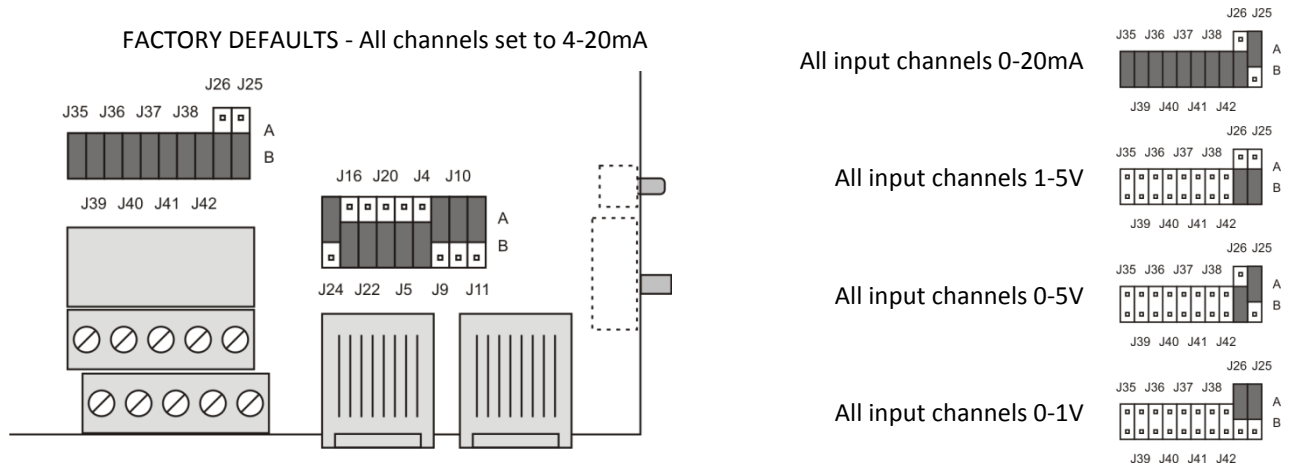

### Digital Inputs

There are two different versions of the AD2006 module with respect to Digital Inputs. There is a low voltage version for nominally 12 or 24 volt inputs, and a high voltage version specifically for 110 volt inputs. The digital inputs are optically isolated to 2.5KV.

- **AD2006<sub>L</sub>** - Lo Voltage    10-35VDC/AC    4k7 Impedance
- **AD2006<sub>H</sub>** - Hi Voltage    70-130VAC/DC    27k Impedance



**Note:** This is not an on-board selectable option, so please ensure that you have the correct version of hardware for your application.

The digital input voltage is marked on the terminal strip label with the 'Lo' voltage inputs in blue, and the 'Hi' voltage inputs in orange.

The digital inputs are supplied in two blocks of 8 inputs each, with a separate common terminal.

The inputs will accept an AC input voltage or a DC voltage of either polarity.

### Pulse Counters

Each Digital Input may be used as a pulse counter up to 5Hz. The first two inputs can be configured as high speed pulse counters up to 5KHz (equal mark space ratio).

- Where the inputs are used as slow counters (to 5Hz), the inputs are usually referred to the digital input common.
- Where the fast pulse counters are used, the inputs are referred to the module 0V supply (ground).

The digital inputs will then accept inputs from common emitter transistors, FETs or reed switches etc. as shown below.

The factory default setting is for all inputs to be configured as digital inputs / slow counters. The following jumper settings apply where inputs 1 or 2 are required to be fast counters.

### Jumper Configurations

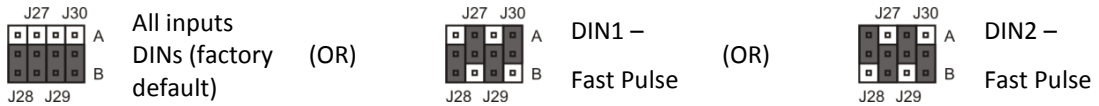

### Digital Input Wiring

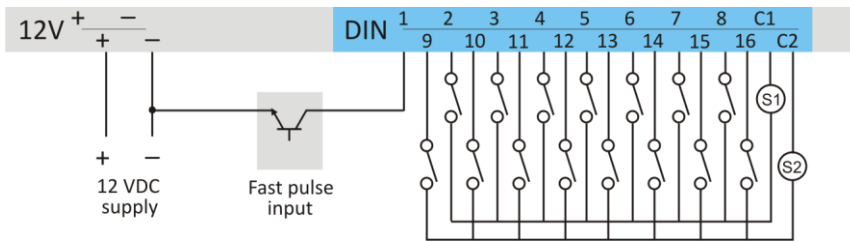

### Digital Outputs

Each of the four Digital Outputs may be individually configured as an isolated relay or common emitter transistor.

#### Isolated Relay Configuration (factory default)

With all jumpers J12 - J15 in position A, the module is configured for 2 SPST and 2 SPDT relay outputs.

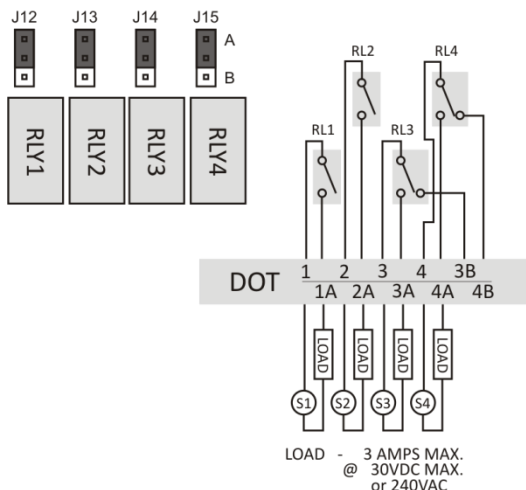

#### Common Emitter Configuration

With all jumpers J12 - J15 in position B, all outputs are common emitter transistors.

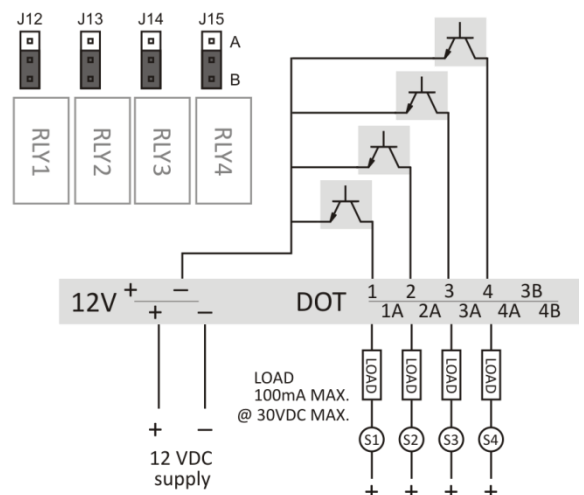

## Ports

### Port 1 – External Radio - FFSK or RS232

Port 1 is intended for connection to an external data radio and provides either FFSK or RS232 options (see External Radio, page 6). See Baud Rate Options, page 6)

- The FFSK option is configurable to 4800 baud.
- The RS232 option can operate up to 115,200 baud.

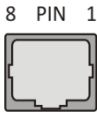
| Pin | Function | (view looking into ext. radio port)   |
|-----|----------|---|
| 1   | CD       |  |
| 2   | RTS      |   |
| 3   | TX Data  |   |
| 4   | PTT      |   |
| 5   | GND      |   |
| 6   | RX Data  |   |
| 7   | CTS      |   |
| 8   | n/c      |   |

### Ports 2 & 5 - RS232

Ports 2 & 5 can both be used for connection to third party devices via RS232. Each port can operate up to 115,200 baud. The on-board selectable options are detailed in the following page of this manual.

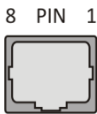
| Pin | Function | (view looking into RS232 port)  |
|-----|----------|---|
| 1   | DTR      |  |
| 2   | RTS      |   |
| 3   | TX Data  |   |
| 4   | PTT      |   |
| 5   | GND      |   |
| 6   | RX Data  |   |
| 7   | CTS      |   |
| 8   | DSR      |   |



**Note:** Port 5 cannot be used as an RS232 port if the Ethernet connection is being used.

### Port 3 - RS485

Port 3 is an RS485 port intended for use as a multi-drop serial connection for I/O expansion modules or third party devices. It can run either Miri protocol or Modbus.

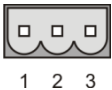
| Pin | Function | (view looking into ext. radio port)   |
|-----|----------|---|
| 1   | CD       |  |
| 2   | RTS      |   |
| 3   | TX Data  |   |

### Port 4 - USB-B

This port is intended for use as a programming port.

### Port 5 - Ethernet Option

The Ethernet port is a factory fitted 10/100T option which can run either Modbus TCP or Miri protocols.



**Note:** Where the Ethernet port is used, Port 5 cannot be used as an RS232 port.

## Radios

There are a number of internal radio options available for the AD2006 modules. Some of these use audio (FFSK) modulation, whereas others have an RS232 interface. External radios can be connected using Port 1. Ports 2 and 5 are also available for RS232 connections.

There is a PTT push button located under the bottom right hand corner of the module for checking the SWR of antenna installations during commissioning.

### Internal Radios

AD2006 Modules come supplied with an internal radio, either UHF or VHF which may be configured as RS232 or FFSK.

The default factory settings for an internal (VHF/UHF) radio RS232@2400 baud are as shown right.

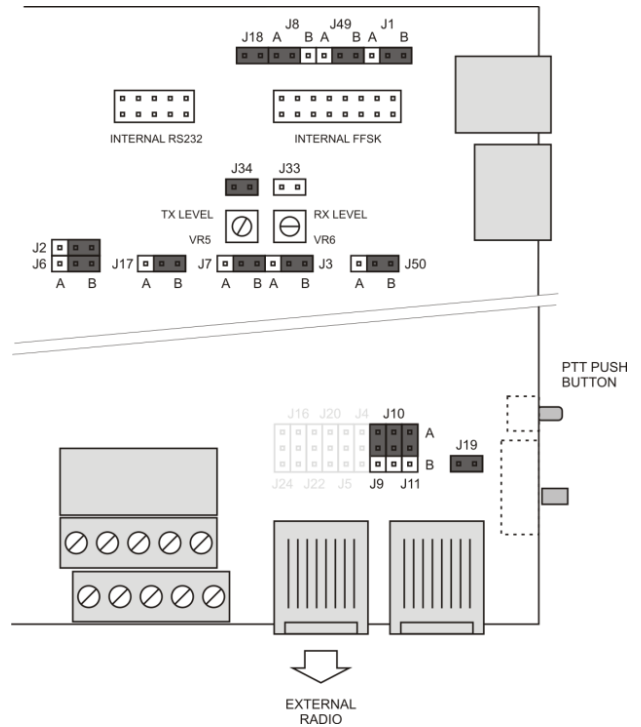

### External Radio

- **FFSK EXTERNAL RADIO** - To configure the module for an external audio radio, make the following changes to J1, J3, J7, J8, J9, J10, and J11.

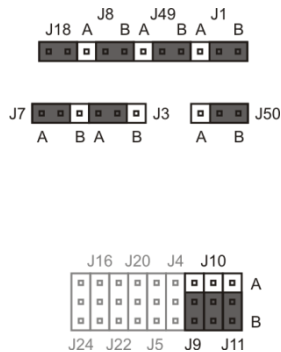

- **RS232 EXTERNAL RADIO CONNECTION** - To configure the module for an external RS232 radio port, make the following changes to jumpers J1, J9, J10 and J11.

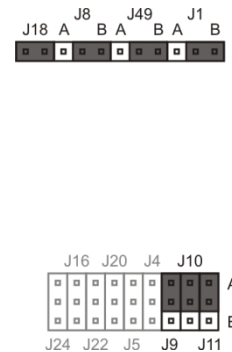

### Baud Rate Options

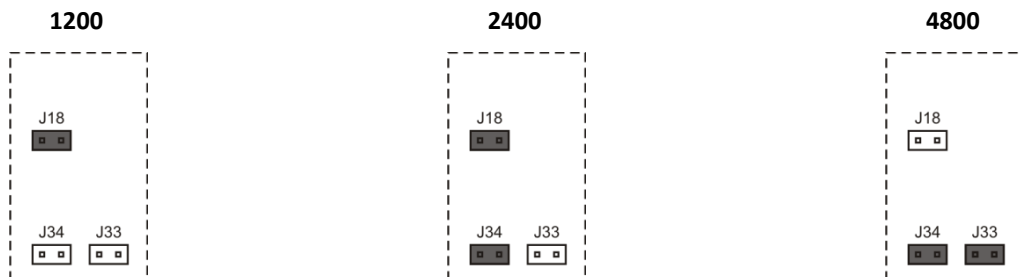

## 4. Options

### Analog Output

An analog output board must be installed to utilise this option. This is a factory fitted option. When the analog board is installed, any of the last four channels can be configured as 4-20mA outputs.

Channels 5 to 8 are selected as 4-20mA outputs by installing jumpers as follows;

- J4 – Position A (Channel 5)
- J5 – Position A (Channel 6)
- J20 - Position A (Channel 7)
- J22 & J16 - Position A (Channel 8)

**Note** - If channel 8 is configured as an analog output, analog input 8 will still operate as a supply voltage monitor, provided that J24 is selected in position A.

**Note** - J9, J10 and J11 are not relevant to the analog channel options.

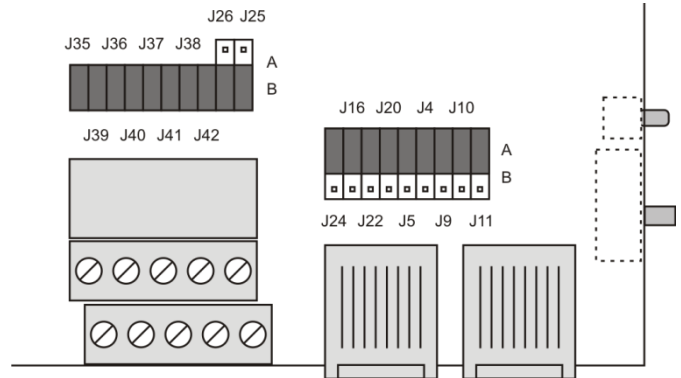

### Power Supply Monitor

Analog input channel 8 is set by factory default to monitor the module's supply voltage. This is particularly useful in solar powered installations.

If channel 8 is required as a normal analog input channel then J24 is moved from position A to position B.

### Voltage Source for Field Sensors

The analog input channel (8) can be configured as a 5V source to power field sensors to a maximum current supply of 20mA. To select this option, install jumpers;

- J16 - position B, &
- J22 - position A.

## 5. Antennas

It is imperative for the reliable operation of your radio telemetry system that the antennas be installed correctly. It is therefore strongly recommended that the services of qualified radio personnel be used for the antenna installations.

The following example is a guide only which shows the salient features relating to the installation of commonly used antennas. These antennas are vertically polarised, which will normally be the case for point to multipoint systems within Australia. In point to point links, the radio license will typically be for horizontally polarised antennas, in which case the YAGI antenna shown would be rotated through 90 degrees.

### Vertically Polarised 450 – 470 MHz Antennas

Typical Mounting Arrangements and Dimensions

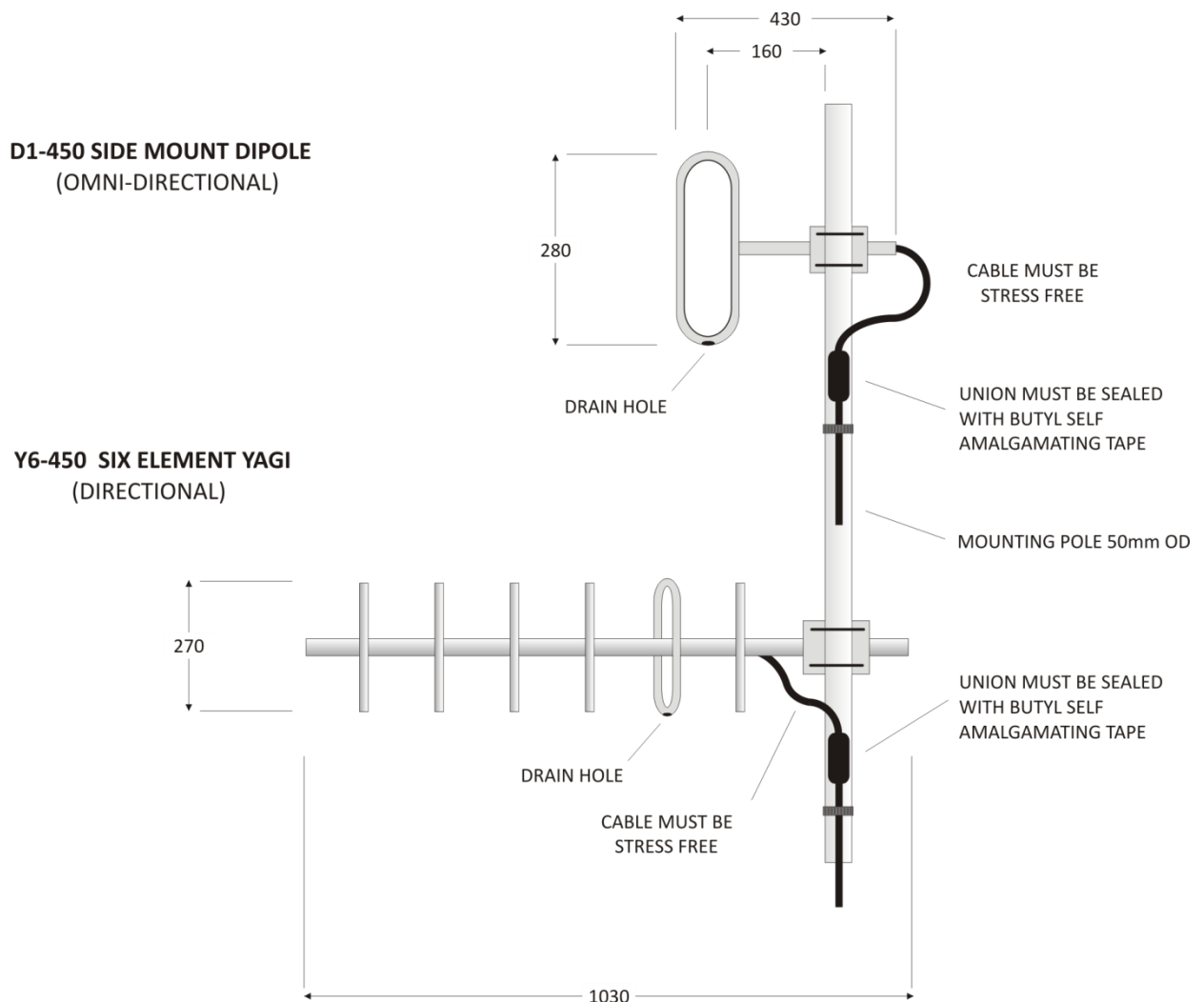

#### Notes:

- All cable connections must be sealed with butyl self-amalgamating tape. PVC tape is not acceptable!
- Antennas should be mounted free from immediate obstructions to provide a clear line of sight in the required direction.
- Standard antenna mounting brackets are designed for 55mm OD pipe.
- The coaxial cable should be stress free and not include any sharp bends.
- The drain hole in the driven element of the antenna must point downwards.

## 6. Wiring & Mounting

### Wiring

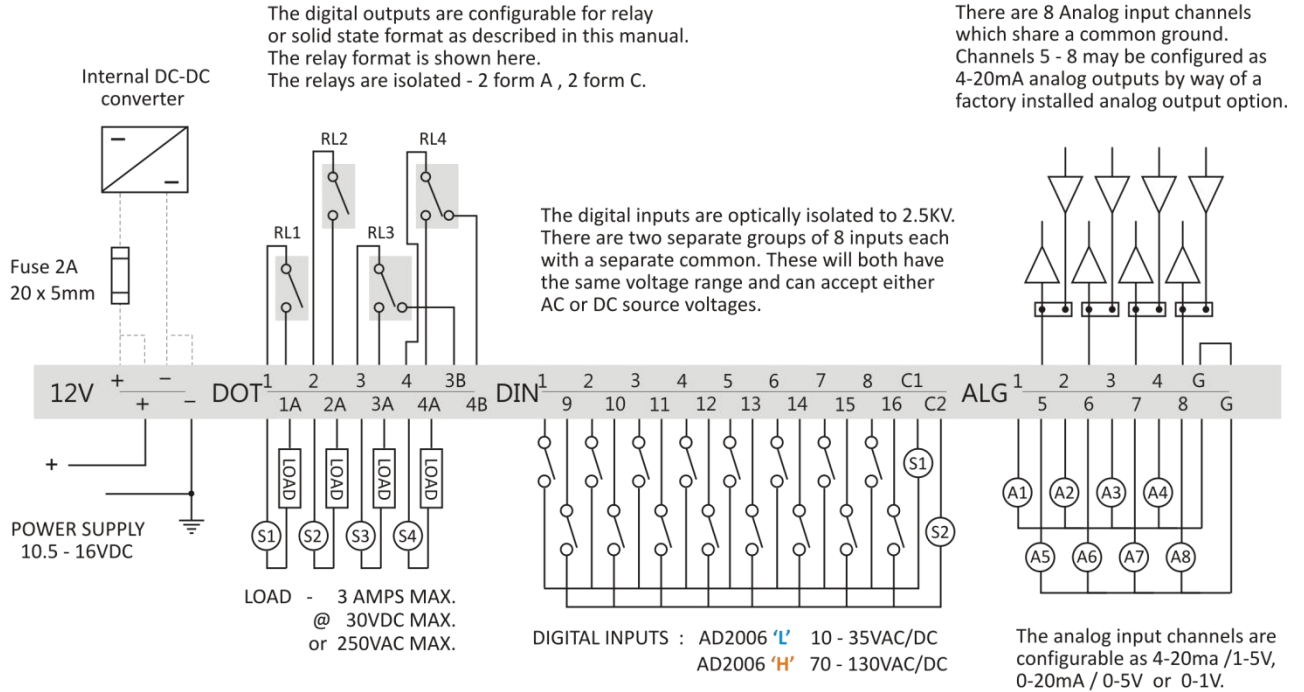

**NEGATIVE SUPPLY & COAXIAL CONNECTION MUST BE GROUNDED**

**PLEASE ENSURE THAT YOU HAVE THE CORRECT INPUT VOLTAGE BEFORE CONNECTION !**

### Mounting

- The AD2006 module is installed by means of the clip in stainless steel mounting bracket supplied with the unit.
- The module is removed by depressing the small tongue at the bottom of the mounting bracket and sliding the unit upwards.
- The terminal blocks are removable such that the I/O wiring need not be disturbed if replacing a module in the field.



**Note:** Please ensure when mounting the telemetry module that sufficient clearance is left for wiring to and from the unit. Recommended minimum clearances are shown right.

