

A Miri Technologies Manual – Version Release1

Wiring Details for the IO Expansion Modules for the AD2000

Miri Technologies

30 Buckingham Drive, Wangara

Western Australia, 6065

PO Box 1116, Wangara, 6947

phone • (61-8) 9409 8998

fax • (61-8) 9409 9229

email • miri@miri.com.au

website • www.miri.com.au

AD2000 IO Expansion Module Specifications

16 point low voltage digital input module

Part Number M16-LN

telemetry + control solutions

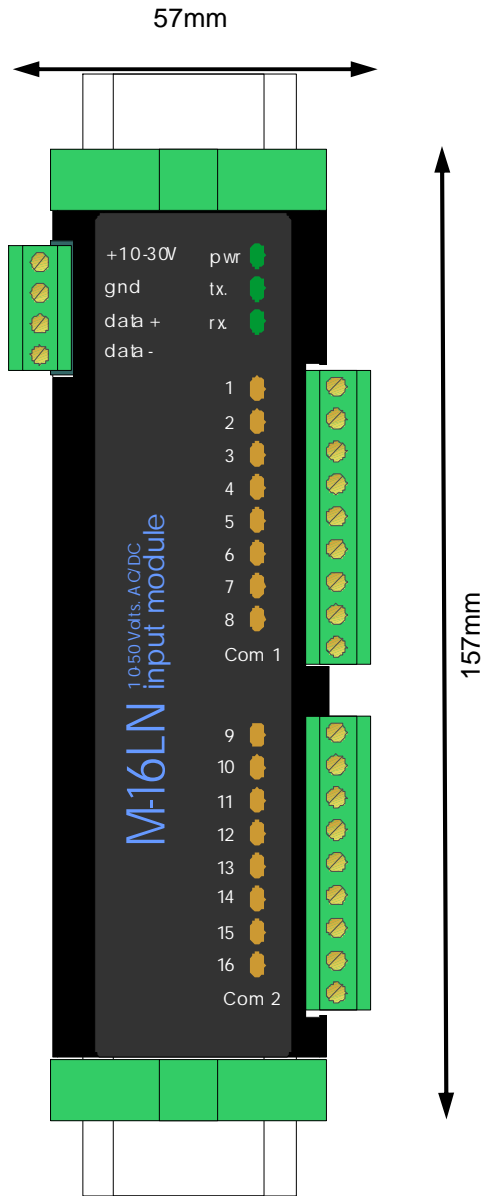

50mm High (including DIN rail)

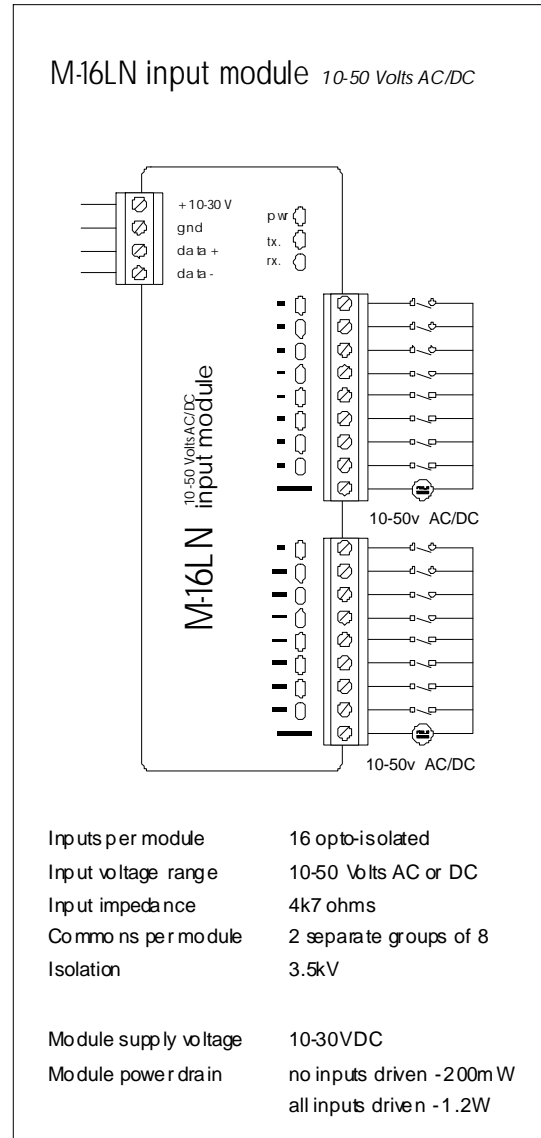

AD2000 IO Expansion Module Specifications

16 point high voltage digital input module

Part Number M16-HN

telemetry + control solutions

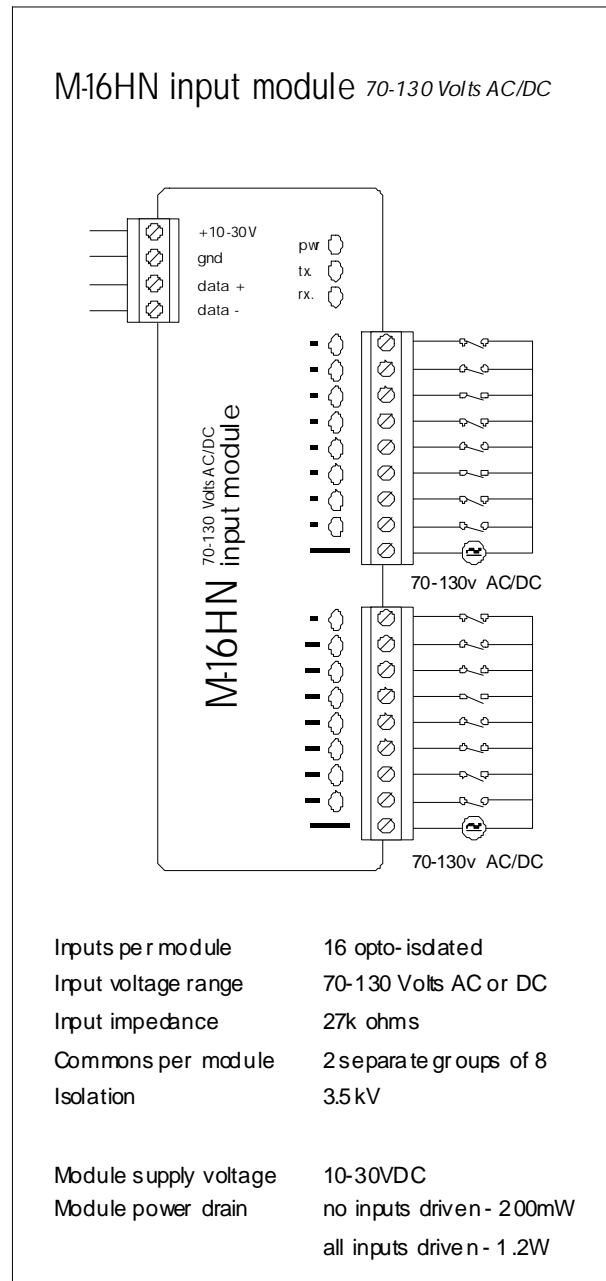
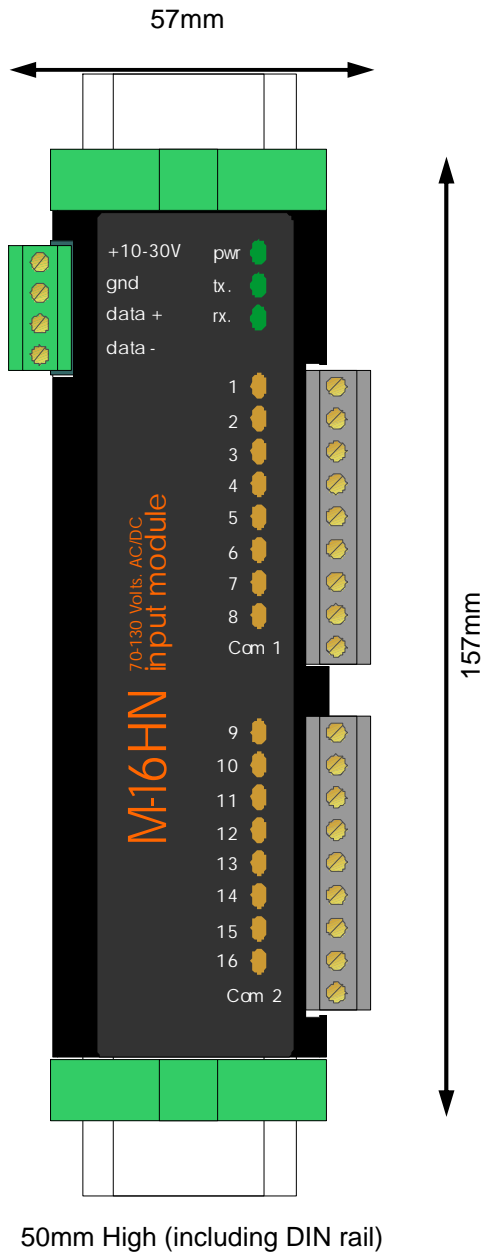

AD2000 IO Expansion Module Specifications

16 point relay output module

Part Number M16-TR

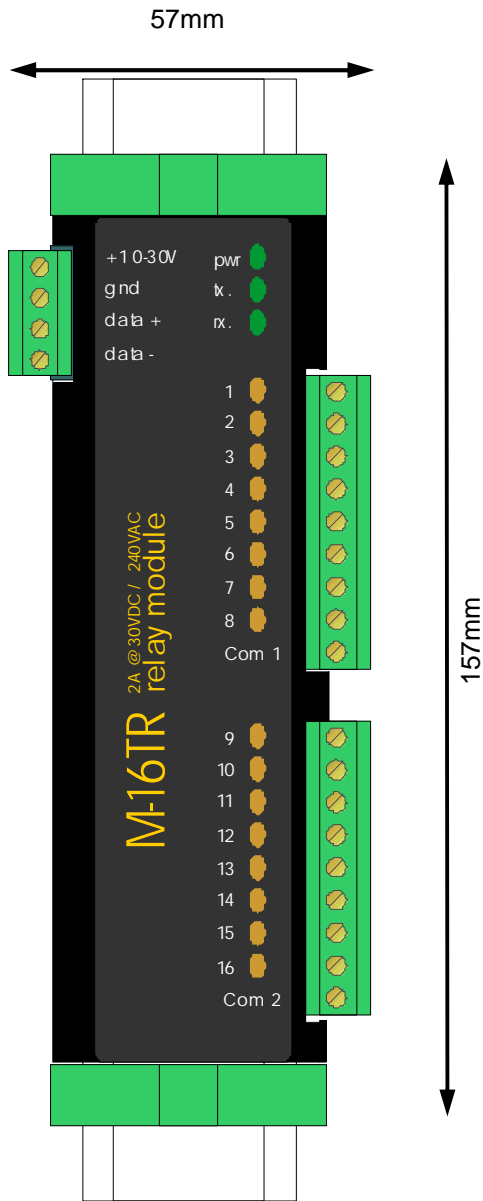

50mm High (including DIN rail)

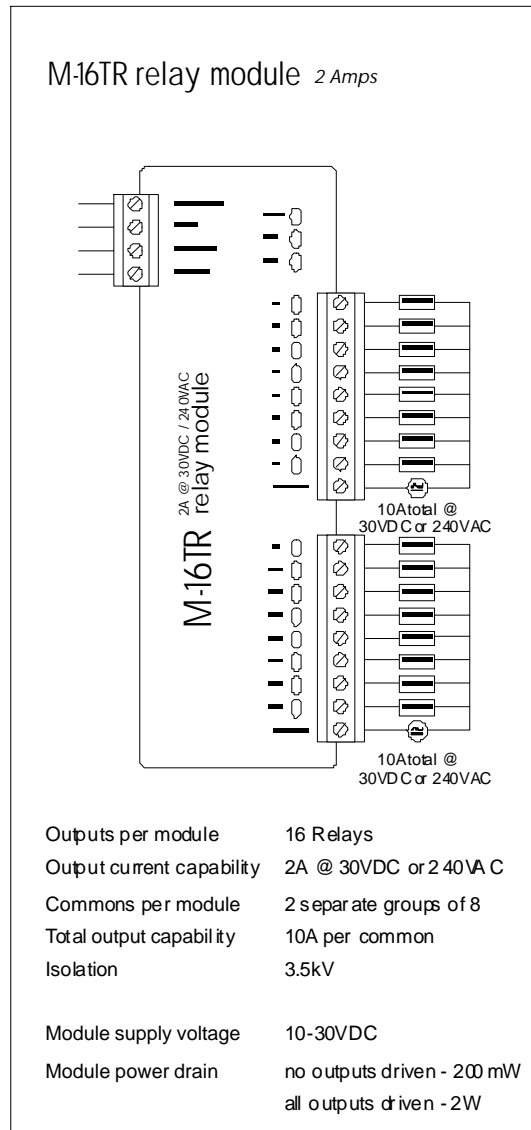

AD2000 IO Expansion Module Specifications

8 channel analog input module

Part Number M8-AD

telemetry + control solutions

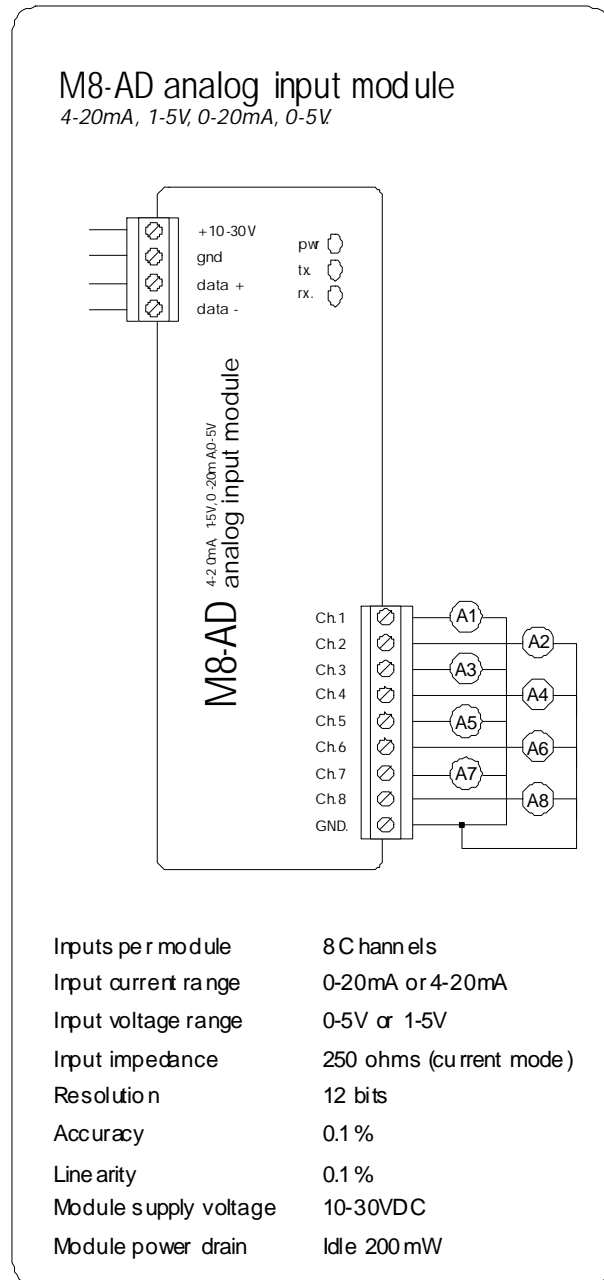
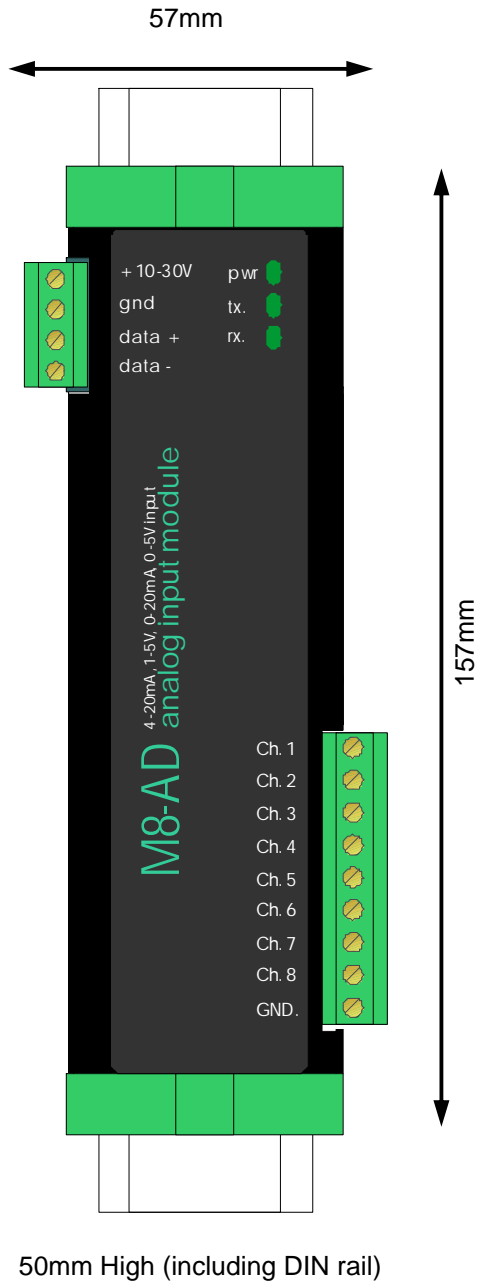

AD2000 IO Expansion Module Specifications

M232-485 RS232 to RS485 converter

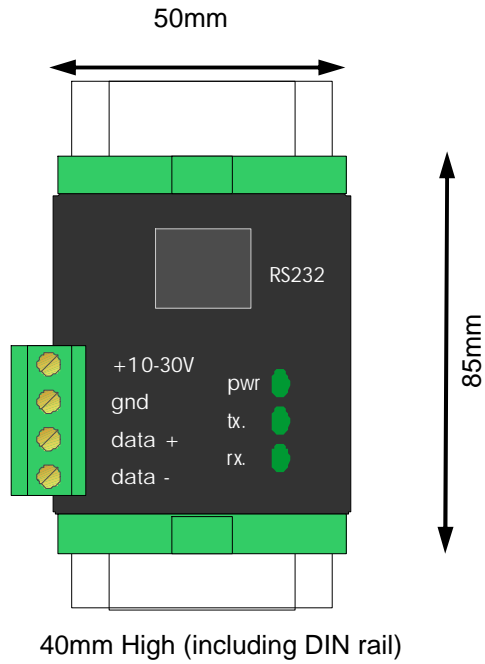

A 10-30VDC power supply is required for the M232-485 converter. This can be the same power supply as used by the IO Expansion modules.

See the following diagram for cable wiring detail between the AD2000 and the M232-485 converter.

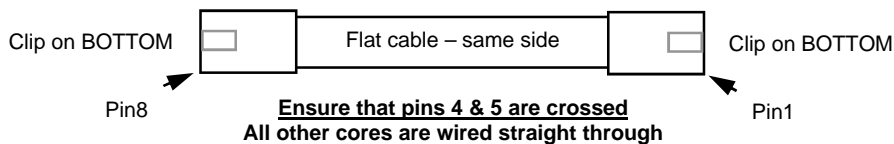
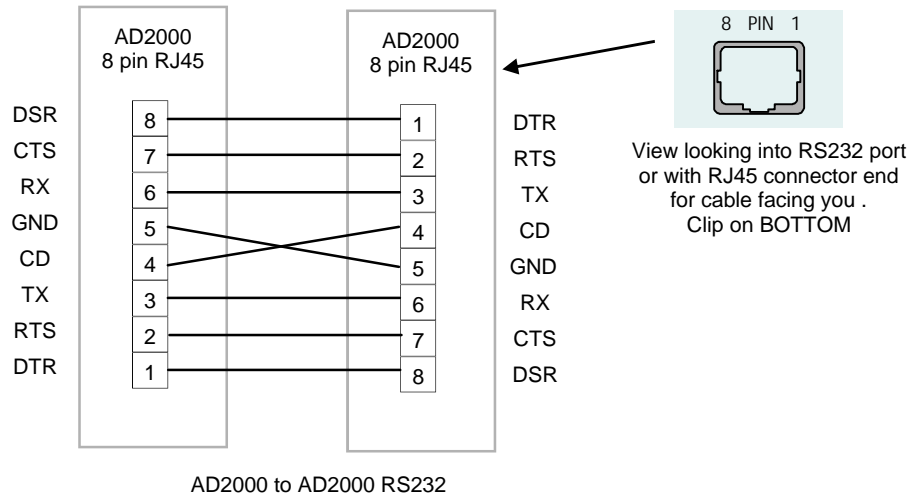

AD2000 IO Expansion Module Specifications

DIP Switch settings

The DIP switch settings are drawn as seen looking into the END of the IO Expansion module (hence they are drawn upside down)

■ Shaded indicates DIP switch position

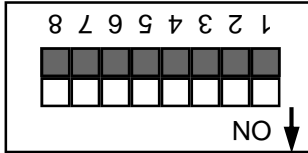

- 1 – 2 Baud Rate
- 3 – Protocol
- 4 – 8 Unit Address

2 1



1 OFF, 2 OFF – 9600



1 ON, 2 OFF – 38400



1 OFF, 2 ON – 57600



1 ON, 2 ON – 115200

NO ↓

3



3 OFF, Default Protocol*

3



3 ON, Modbus RTU**

NO ↓

* Use the Default protocol setting for use with the AD2000 Programming software package.

** Modbus RTU is available for use with other devices as required (and all IO points are mapped to Holding Register 1 for read and write (input and output) devices, e.g. Modbus address 40001).

8 7 6 5 4 [DIP Switch Diagram] 8 7 6 5 4	Address=1	8 7 6 5 4 [DIP Switch Diagram] 8 7 6 5 4	Address=17
8 7 6 5 4 [DIP Switch Diagram] 8 7 6 5 4	Address=2	8 7 6 5 4 [DIP Switch Diagram] 8 7 6 5 4	Address=18
8 7 6 5 4 [DIP Switch Diagram] 8 7 6 5 4	Address=3	8 7 6 5 4 [DIP Switch Diagram] 8 7 6 5 4	Address=19
8 7 6 5 4 [DIP Switch Diagram] 8 7 6 5 4	Address=4	8 7 6 5 4 [DIP Switch Diagram] 8 7 6 5 4	Address=20
8 7 6 5 4 [DIP Switch Diagram] 8 7 6 5 4	Address=5	8 7 6 5 4 [DIP Switch Diagram] 8 7 6 5 4	Address=21
8 7 6 5 4 [DIP Switch Diagram] 8 7 6 5 4	Address=6	8 7 6 5 4 [DIP Switch Diagram] 8 7 6 5 4	Address=22
8 7 6 5 4 [DIP Switch Diagram] 8 7 6 5 4	Address=7	8 7 6 5 4 [DIP Switch Diagram] 8 7 6 5 4	Address=23
8 7 6 5 4 [DIP Switch Diagram] 8 7 6 5 4	Address=8	8 7 6 5 4 [DIP Switch Diagram] 8 7 6 5 4	Address=24
8 7 6 5 4 [DIP Switch Diagram] 8 7 6 5 4	Address=9	8 7 6 5 4 [DIP Switch Diagram] 8 7 6 5 4	Address=25
8 7 6 5 4 [DIP Switch Diagram] 8 7 6 5 4	Address=10	8 7 6 5 4 [DIP Switch Diagram] 8 7 6 5 4	Address=26
8 7 6 5 4 [DIP Switch Diagram] 8 7 6 5 4	Address=11	8 7 6 5 4 [DIP Switch Diagram] 8 7 6 5 4	Address=27
8 7 6 5 4 [DIP Switch Diagram] 8 7 6 5 4	Address=12	8 7 6 5 4 [DIP Switch Diagram] 8 7 6 5 4	Address=28
8 7 6 5 4 [DIP Switch Diagram] 8 7 6 5 4	Address=13	8 7 6 5 4 [DIP Switch Diagram] 8 7 6 5 4	Address=29
8 7 6 5 4 [DIP Switch Diagram] 8 7 6 5 4	Address=14	8 7 6 5 4 [DIP Switch Diagram] 8 7 6 5 4	Address=30
8 7 6 5 4 [DIP Switch Diagram] 8 7 6 5 4	Address=15	8 7 6 5 4 [DIP Switch Diagram] 8 7 6 5 4	Address=31
8 7 6 5 4 [DIP Switch Diagram] 8 7 6 5 4	Address=16	8 7 6 5 4 [DIP Switch Diagram] 8 7 6 5 4	Address=32

NO ↓

NO ↓

AD2000 IO Expansion Module Specifications

Typical Wiring layout and Arrangement

One M232-485 converter is required between the AD2000 port and the IO Expansion modules to convert between RS232 and RS485 signals. RTS control must be available on the RS232 port for correct operation.

The AD2000 port must be configured in the configuration software Port Properties with the interface set to:

Interface: IO Expansion
Polling: Continuous
RTS During Tx must be checked.
Baud Rate 38.4K

N.B. Protocol must match DIP switch 3 setting on IO Expansion module.

The diagram to the right is a typical wiring and layout diagram – RS485 wires are connected straight NOT crossed and looped in parallel not in a star arrangement. Use shielded, twisted pair cable complying to the EIA RS485 standard and ensure lengths conform to RS485 specifications. Balance resistors (220Ω) may be required at each end (the first and the last device) on long cable runs.

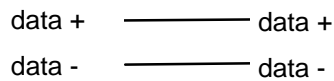

Up to 32 IO Expansion modules can be supported on one AD2000 port (subject to the use of correct RS485 cabling and termination).

